

Cedric Price

# FUN PALACE

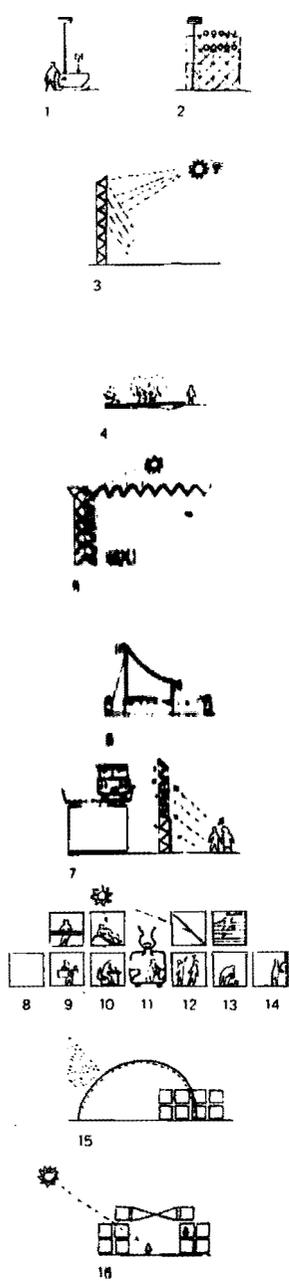

- 1 mobile electronic projection units
- 2 external lighting banks
- 3, 6, 7 tridetic spacelike structures with thermal, visual and acoustic baffles
- 4 free-standing flooring panels
- 6 projection screens for external use
- 8-14 standard demountable cubes with various panel infills, stairs, floors, doors, etc
- 15 inflatable structures: purpose made
- 16 plasticised nylon tensioned canopies

progress in basic problems of enclosure and movement is not merely depressing but also extremely dangerous. It is a cause for total concern when one of the major obstacles to the improvement through change of many activities is primarily hampered by the restriction of their enclosures.

No example is clearer than that of large industrialised cities and conurbations. Here, not only convenience is marred, but the actual potential of twentieth-century urban living remains unexploited due to the criminally long-lasting dross in which the community is housed. In addition, much new planning and design, often resulting in building legislation, is of the 'band-aid' variety. Thus, when the first feasibility study was done on the validity of providing a particular structure to encourage the aims of Joan Littlewood's Fun Palace concept it was essential that any proposed design should reinforce the activities housed in it.

In addition, since the social concept of the Fun Palace is primarily a people's workshop or university of the streets, the self-participatory element of the activities must extend to a degree of control by the users of their physical environment.

Inbuilt flexibility or its alternative, planned obsolescence, can be satisfactorily achieved only if the time factor is included as an absolute design factor in the total design process. Such calculated awareness of the time factor related to the enclosing of activities and their interrelationship must extend to an assessment of the valid life-span of the total complex, assessed primarily in socio-urban terms.

This, in relation to the London siting of the Fun Palace, has been fixed at ten years. There is a large degree of, one hopes inspired, guesswork in this figure.

However, having fixed it, it provides an extremely definitive range of requirements and aims in the determination of means of access, site, structural system, materials, servicing and component design of the whole. . . .

Immediate site considerations include the utilising of the adjacent areas and buildings as additional environmental conditioners. The majority of the adjacent development is industrial, part-derelict, and productive of noise, dust and noxious fumes. Such surroundings would be detrimental to a small single-cell social amenity building, but in relation to the Fun Palace they can be controlled or even exploited. Thus gas holders are illuminated from the main structure, while derelict areas are converted into varied pedestrian approach and viewing routes.

In order to achieve the degree of flexibility in the provision of activity enclosures it is necessary to be able to rapidly construct such enclosures from a limited kit of parts and for the final particular variation or tuning-up to depend on the additive use of environmental control equipment. Required enclosures, whether total or partial, can be roughly divided into two categories -

Kitchens, restaurants, workshops and lavatories are included in the first category while auditoria, cinema and meeting halls come in the second.

Although most of the listed activities and amenities offered are already available to an urban, or at least metropolitan, public their inter-accessibility achieved by juxtaposition not only enhances freedom of choice, but also creates new activities, at present without name, which result from this concentrated fluidity.

The positive delight in changing one's mind, spying and eavesdropping is catered for without damage to the particular activity.

Flexibility in the construction and destruction of enclosures is alone insufficient to achieve the degree of immediacy of change required by the brief. Thus means of movement and access throughout the complex also needed to be capable of adjustment. Therefore with the exception of the fixed three-dimensional grid of means of escape, all the public movement routes above the totally unobstructed ground level are capable of adjustment. The radial, base-fixed escalators from the ground deck give varied access above ground while portable walkways - moving and static, level and inclined - are fixed in conjunction with decks of particular activities.

Re-routing through the whole complex is capable of rapid change which takes into account evident desire lines on the part of the users.

The degree of spatial variation resulting from participant motivation is comparatively high. The control of the physical environment, due to the size of the structure and the inbuilt equipment, such as the high-level suspension grid and full-span travelling crane, is achieved by an additive rather than total method. That is, adverse conditions are eliminated separately rather than collectively and affinity grouping of activities is related to physical as well as social conditioning.

Such control simplifies the nature of particular barriers or screening and can be contrasted with the total control required over noise, heat, dust, moisture and vibration in the thin walling of an automobile.

The materials used in the construction of the enclosures require a far shorter life-span than the ten years allotted to the protected steel of the overall framework. Their application and use will in themselves provide useful test-bed conditions while their limited life will prevent unnecessary prolongation of the pattern of activity they house.

The whole complex, in both the activity it enables and the resultant structure it provides, is in effect a short-term toy to enable people, for once, to use a building with the same degree of meaningful personal immediacy that they are forced normally to reserve for a limited range of traditional pleasures.

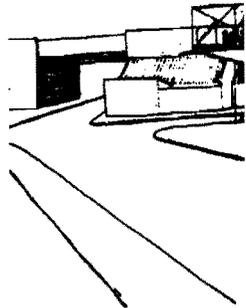

● daytime use with footbridge



● night-time use with mobile lighting

high degree of servicing and lower degree of servicing. Workshops and lavatories are primary while auditoria, cinema are secondary. The second. Recreational activities and amenities are secondary to an urban, or at least inter-accessibility achieved through various chances freedom of choice, and, at present without name, a sense of entrained fluidity. Engaging one's mind, spying on others for without damage to the

protection and destruction of the environment to achieve the degree of service defined by the brief. Thus means a balance throughout the complex of adjustment. Therefore a three-dimensional grid of public movement routes and ground level are capable of base-fixed escalators from access above ground while being dynamic and static, level and in conjunction with decks of

The whole complex is capable of taking into account evident desire for variety. The variation resulting from a comparatively high. The environment, due to the size of the equipment, such as the and full-span travelling additive rather than total conditions are eliminated collectively and affinity oriented to physical as well as

the nature of particular can be contrasted with the noise, heat, dust, moisture resulting from an automobile. The construction of the shorter life-span than the ten-year life-span of the overall operation and use will in test-bed conditions while unnecessary prolongation of life by house. Both the activity it enables and the pleasure it provides, is in effect a pleasure, for once, to use a space of meaningful personal pleasure normally reserved for special pleasures.

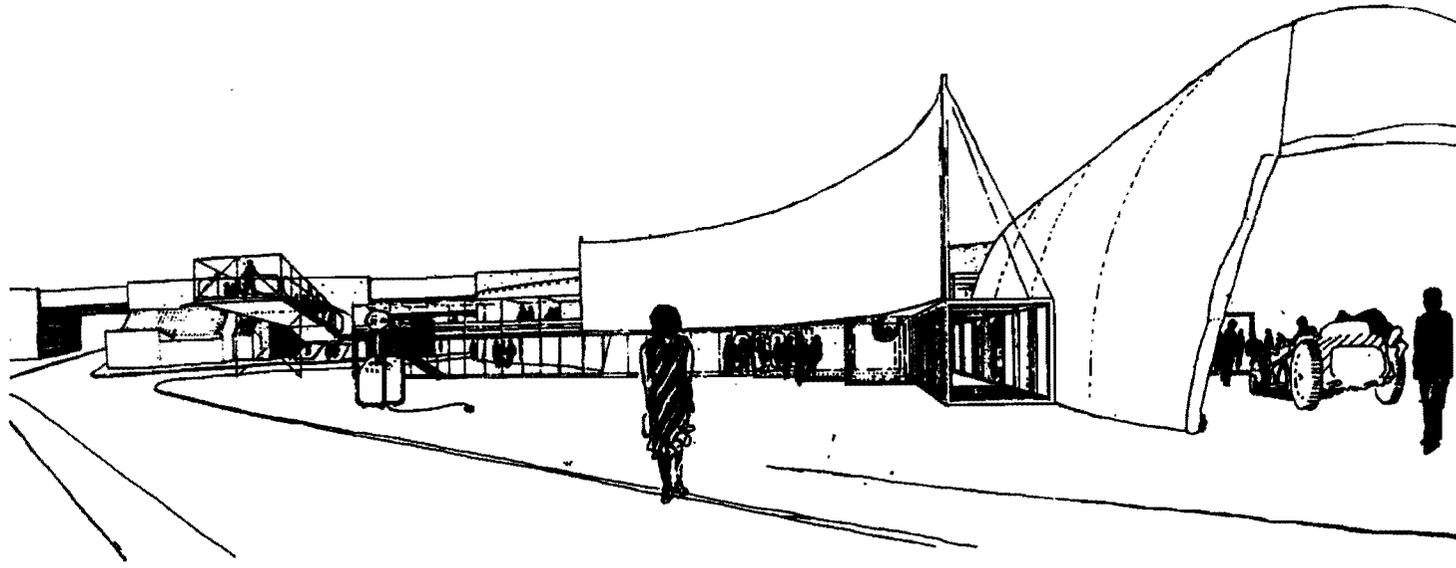

● daytime use with footbridge, climbing frames and air-structured exhibition hall

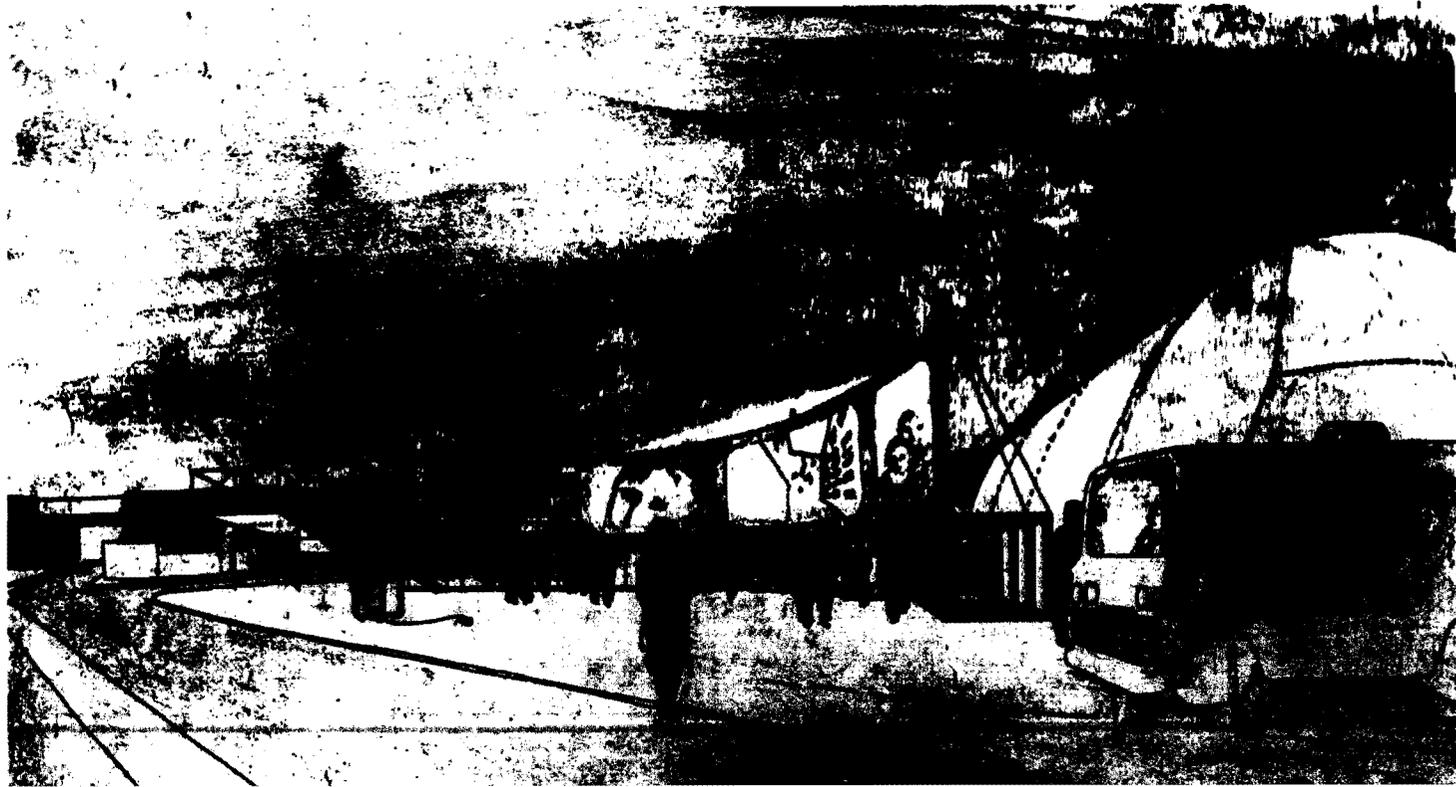

**FUN PALACE**

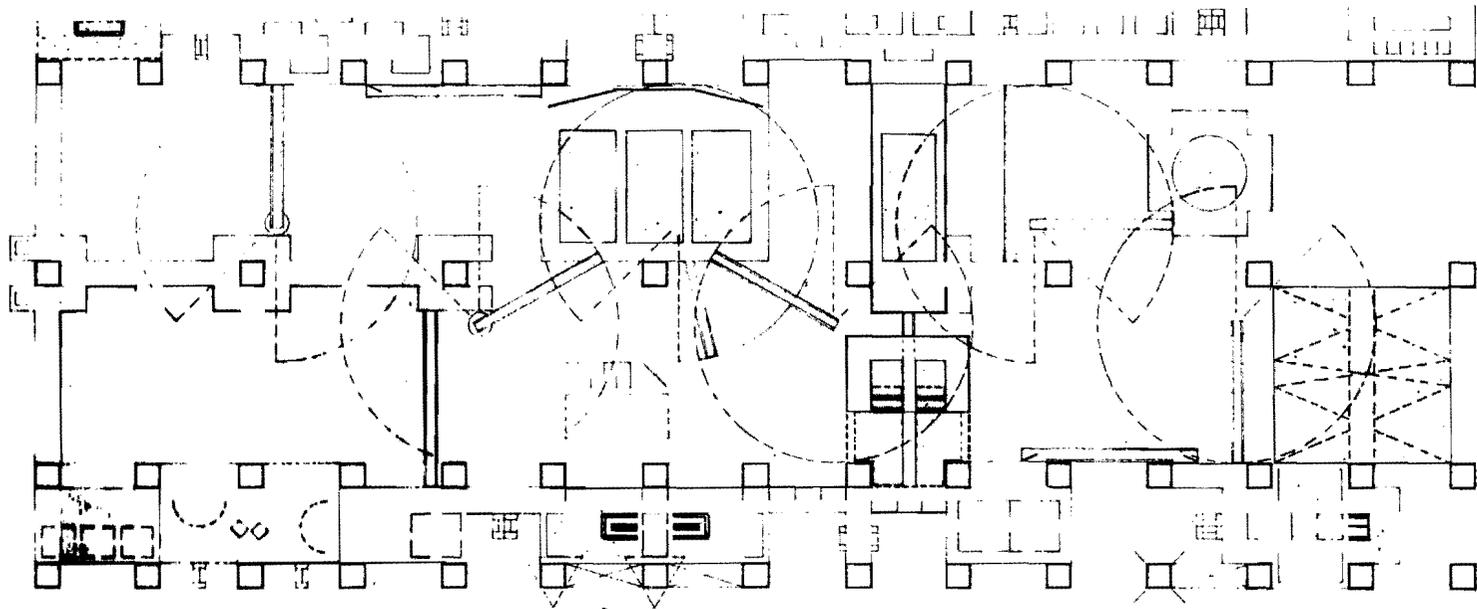

● typical high-level layout

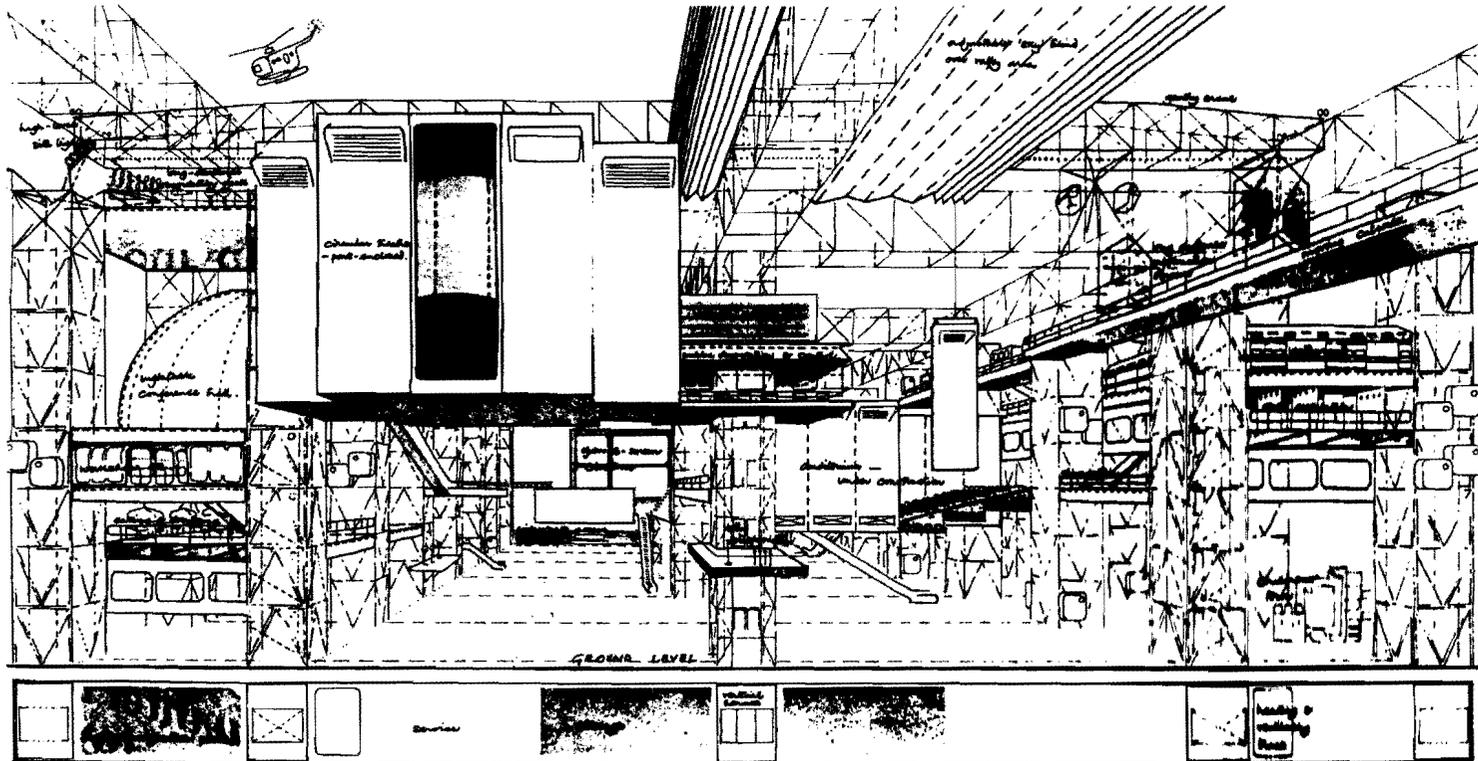

...D LEA  
 ...tube or  
 ...lock a  
 ...I show  
 ...entrance  
 ...stairs or  
 ...Look at  
 ...reaver or v

...bus, monorail  
 ...time YOU want  
 ...pass. The lift  
 ...happening. No  
 ...In anywhere. No  
 ...stires: it's up to you  
 ...a lift, a plane, an  
 ...looks interesting.

...HOOSE what you want to do - or want  
 ...ing it. Learn how to handle tools  
 ...achinery, or just listen to your favo  
 ...or be lifted up to where you can  
 ...make things work. Sit out  
 ...and tune in to what's happening  
 ...starting a riot or beginning a  
 ...back and stare at the sky.

...WHAT TIME... why time  
 ...on summer... doesn't  
 ...the roof will stop the rain but  
 ...The arti  
 ...Social cloud will keep you cool  
 ...you. Your feet will be warm  
 ...the atmosphere clear as you  
 ...not have your homework done  
 ...watch the thunderstorm?

...THIS LOT? I  
 ...the share  
 ...1822  
 ...which all  
 ...that a  
 ...

● centre-spread of original fund-raising folder

sentimental as vest  
 going to argue too ha  
 unsentimental - and v  
 - is that she and her  
 offering any kind of m  
 any-wise. It really is a  
 Cedric Price, the arch  
 architectural journalis

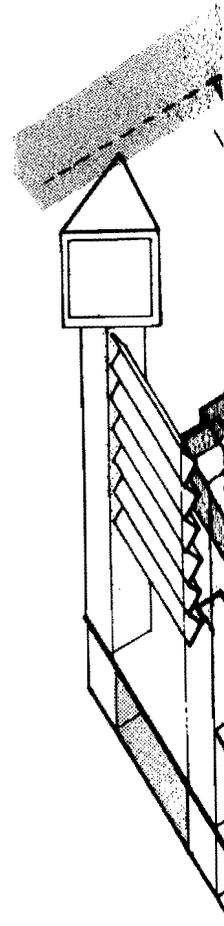

● Two of the fourteen bays

Joan Littlewood: "People deserve all-new tackle, and if she believes this for reasons as sentimental as Weaver's, a lot of the people aren't going to argue too hard about her motives. But what is unsentimental - and why the Fun Palace gets my vote - is that she and her architects and tech-men aren't offering any kind of monument, new, second-hand or any-wise. It really is a kit of parts, and for months now Cedric Price, the architect involved, has been driving architectural journalists mad by steadfastly refusing to

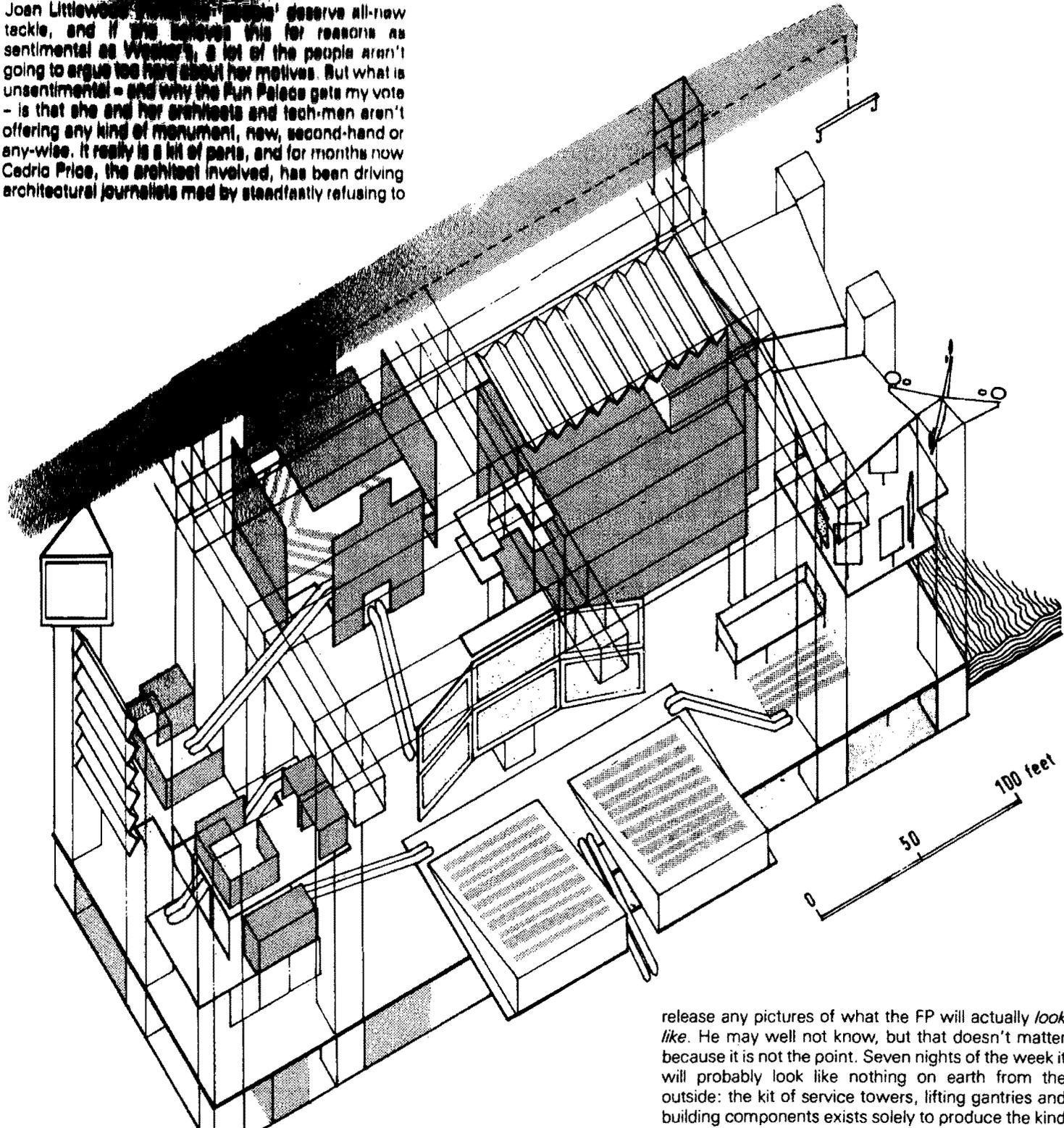
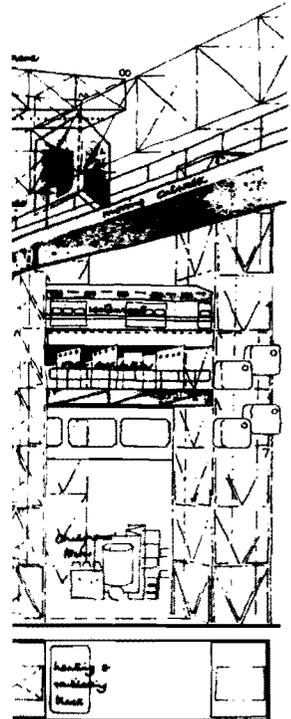
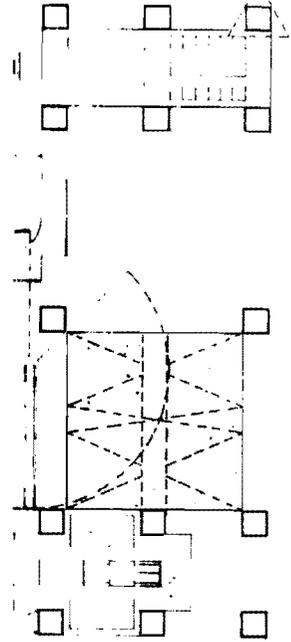

release any pictures of what the FP will actually *look like*. He may well not know, but that doesn't matter because it is not the point. Seven nights of the week it will probably look like nothing on earth from the outside: the kit of service towers, lifting gantries and building components exists solely to produce the kind

LOT? ... nation is to ... great ... 1961

FUN PALACE

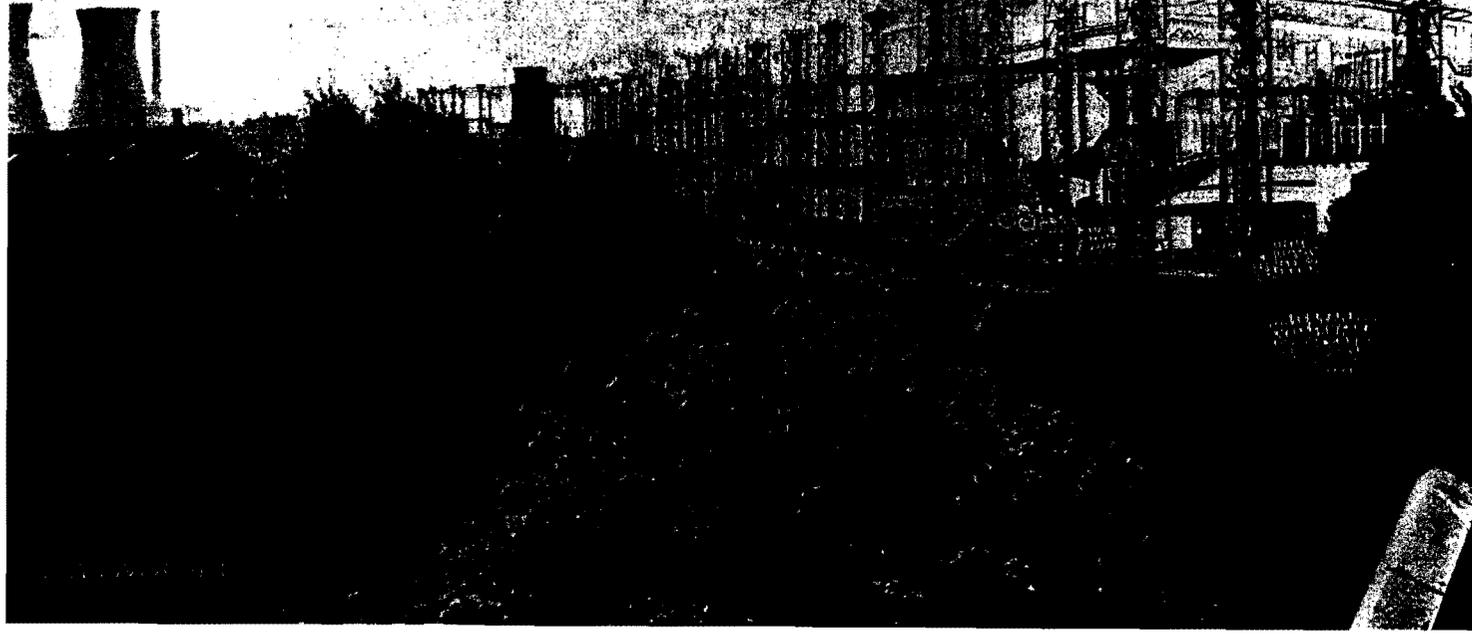

● night-time view at Lea River, London E15

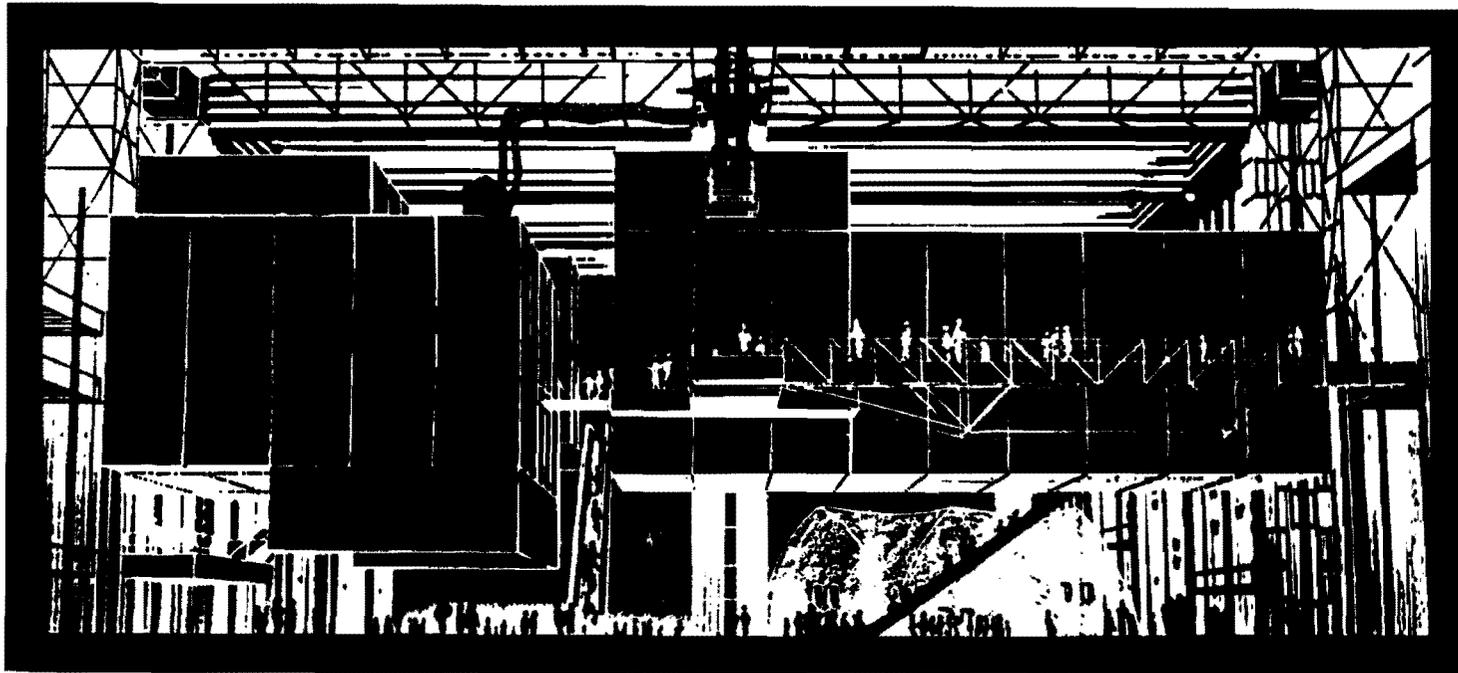

● two suspended auditoria with independent conditioning packages and access bridges



● arriving by helicopter



● three-gallery open air



Essential to eliminate unreal division between leisure time and work time in relation to the personal mental/perceptual pitch exercised. . . .

Architectural and planning attention should primarily increase the *range of choice* of activities and not merely increase the amenity value of existing situations.

Conscious planning now required since the required use of space dependent on activities is, through increasing complexity and frequency of use, no longer sufficient to achieve maximum amenity value. (Compare organisation of village communal space, the village green, for both maypole and ducking stool with Golden Mile, Blackpool.)

Short-term planning: use must be made of communal areas and networks as found, but this use, due to change in activities, may be quite different from the original and is likely to be increasingly specialised - for example, the varied use of urban parks. . . .

Long-term planning: a pleasure network, national or regional, can establish distances and locations directly related at any time to social capabilities and appetites *if it is not* integrated with other required networks.

Such planning must allow for ordered increases but not suggest direction of appetites. . . .

C.P. Summary of 'Planning for pleasure', delivered to the

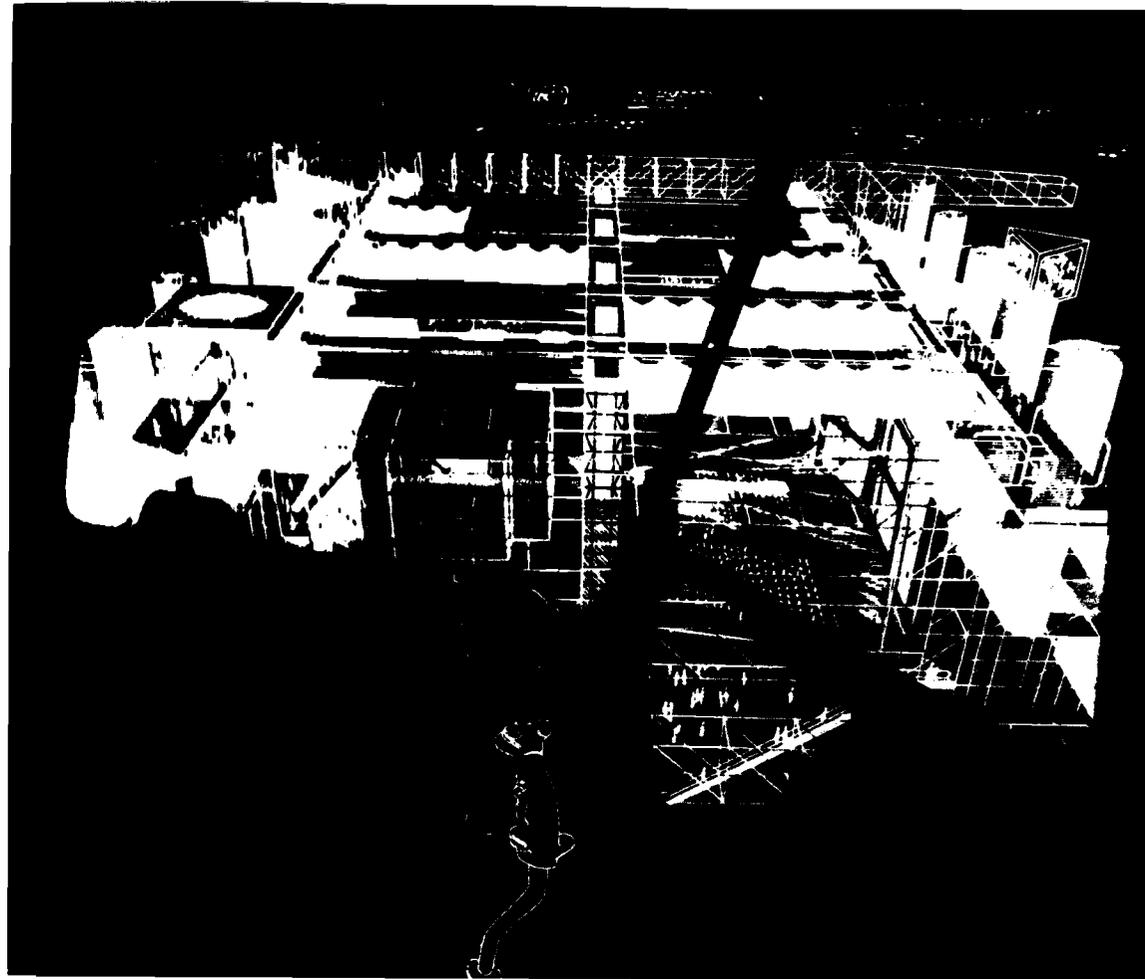

● arriving by helicopter

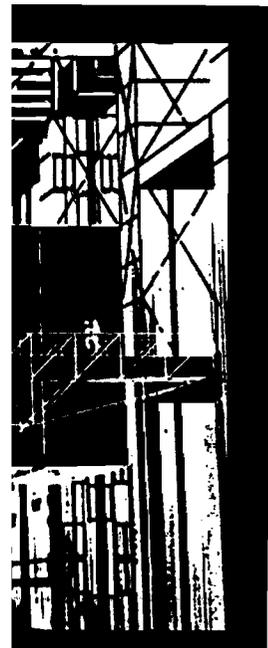
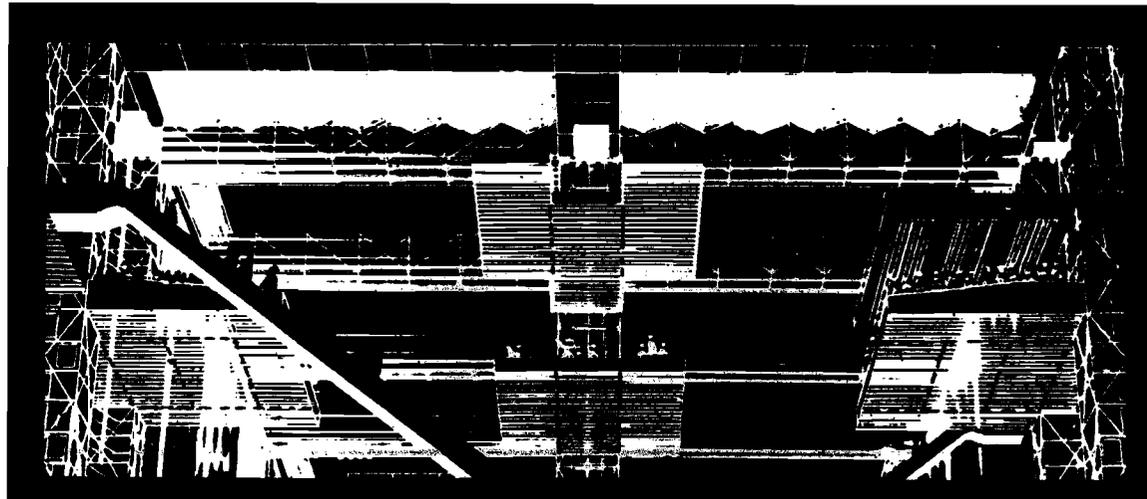

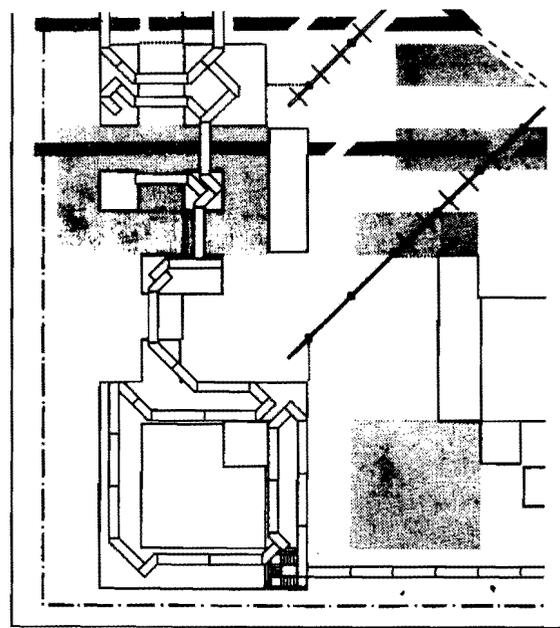
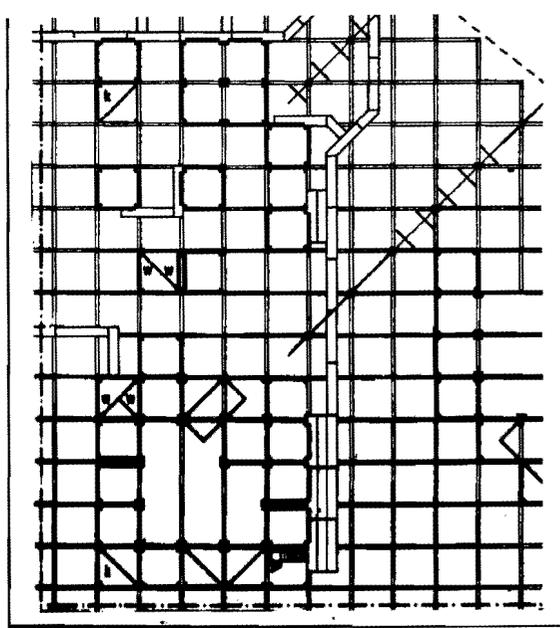

Instantaneous architectural response to a particular problem is too slow. Architecture must concern itself continually with the socially beneficial distortion of the environment. Like medicine it must move from the curative to the preventive. Architecture should have

little to do with problem solving - rather it should create desirable conditions and opportunities hitherto thought impossible.

With this intention the client asked me to investigate whether architecture could help in providing such

conditions for the individ  
inside and outside the  
feasibility study proving  
born - an architectural c  
and no predefined use, (

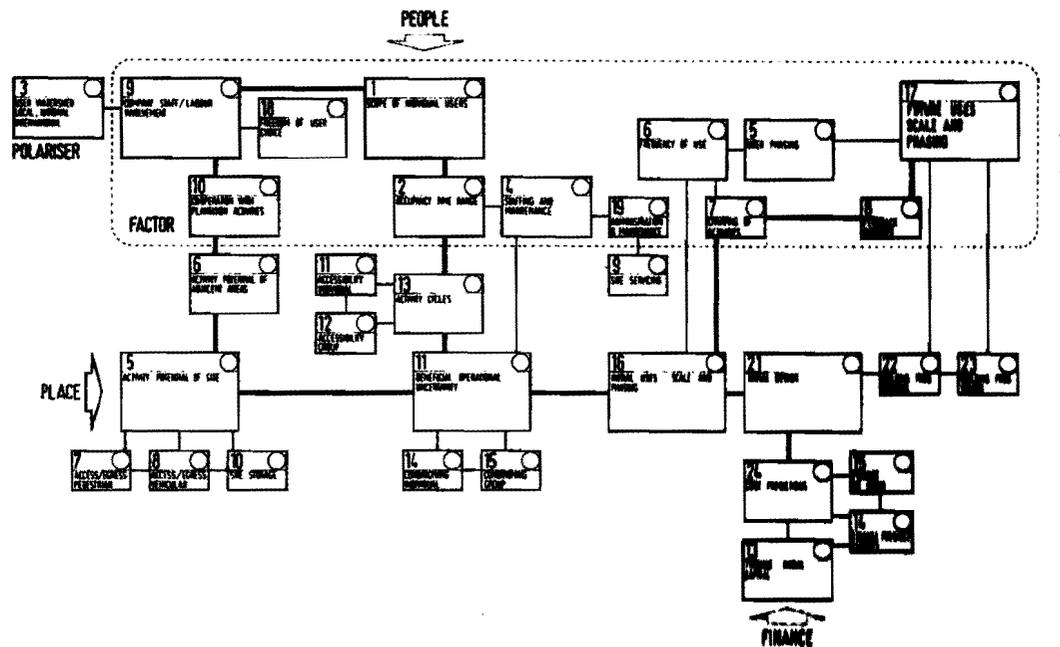

● initial design network with three starting points - people 1, place 5, and finance 13

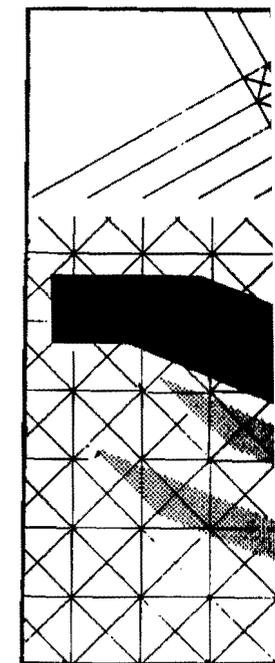

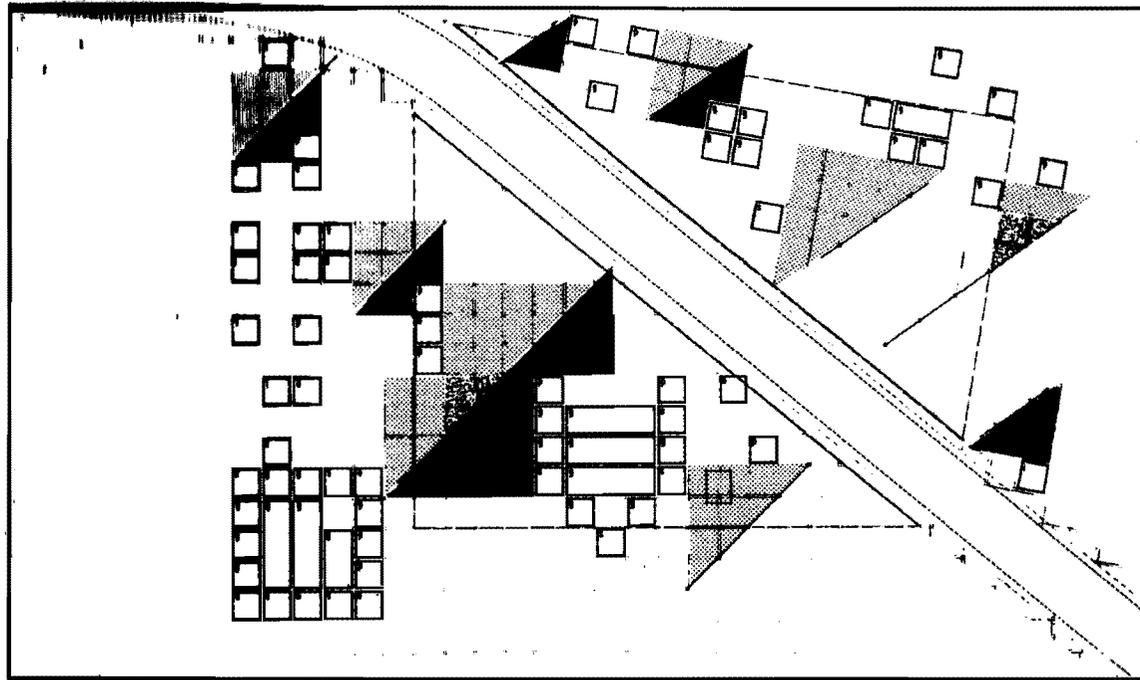
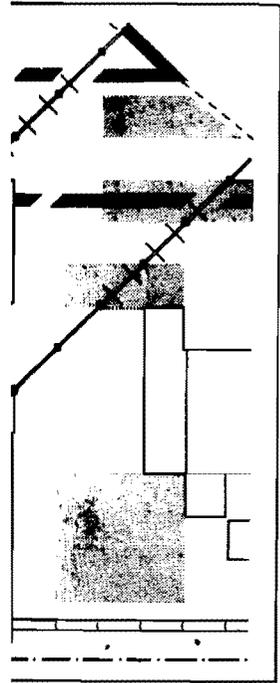

● grid layout + menu 23 + external spaces showing single, double and triple cubed units

Criteria for demarcation of an outside space defined by a combination of screens and cube faces:

- 1 The plan form of the spaces will be an isosceles triangle due to the geometry of both the screens and cubes.
- 2 One plane of the space will be defined by a number of screens. This plane will form the hypotenuse of the triangle.
- 3 The second plane of the triangle (length *x*) will be formed by the faces of a number of cubes (*y*) which lie in the plane but are not necessarily adjacent.
- 4 The third plane of the triangle may be formed in a similar manner to the second plane or may be implied by the combined effect of the hypotenuse and second plane.
- 5 The degree of enclosure of the space by the screens and cube faces is given by

$$\frac{x}{y} < 3.$$

olving - rather it should and opportunities hitherto

it asked me to investigate help in providing such

conditions for the individual and the group from both inside and outside the company. The subsequent feasibility study proving positive, the Generator was born - an architectural complex with no previous title and no predefined use, only a desired end-effect.

Sited in Florida, the Generator's services and structures respond to the users' wishes with help from both crane and computer. C.P.

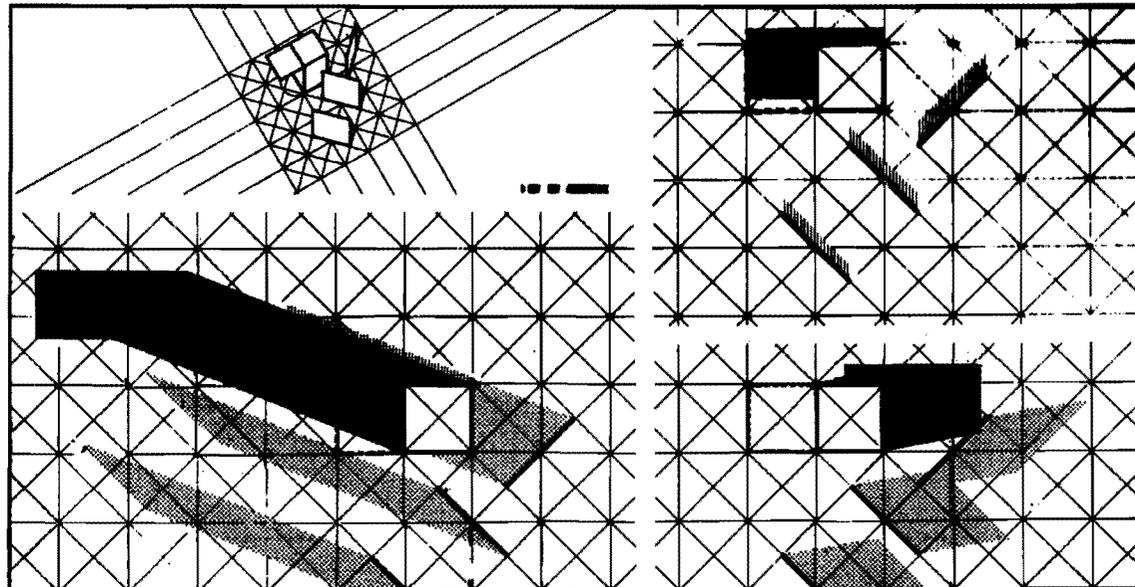
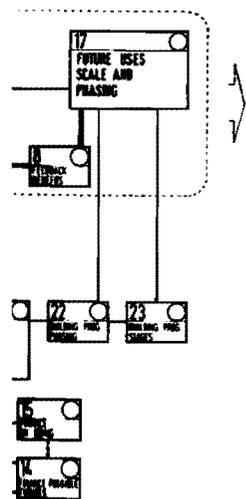

● shadow study of single unit-hinged wall and three screens: 06.00, 12.00, 20.00, June 22

optional shadows

GENERATOR

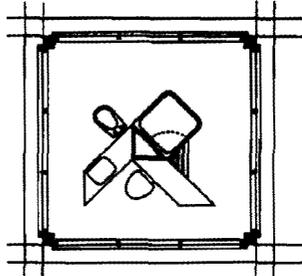
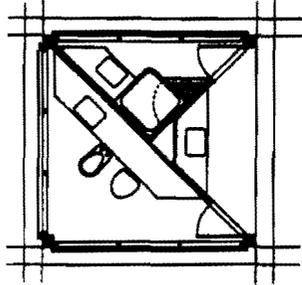
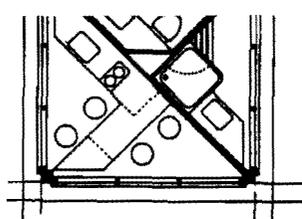

● various wet serviced cubes

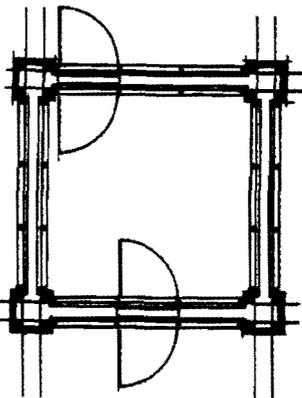

● typical internal cube

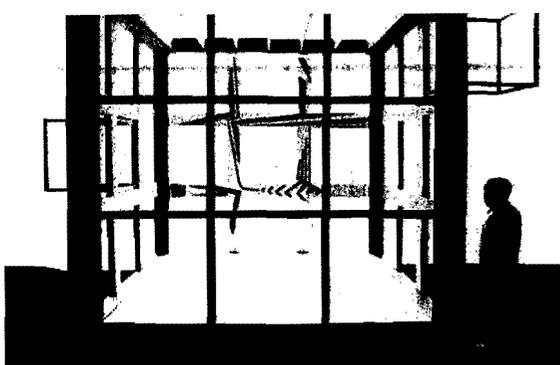

Timber seemed to be the best material to be used for the structure of the stiff-jointed frame boxes. The main structural problem was the fixing to the ground to allow easy positioning and levelling. The idea of hurricane help was suggested whereby the boxes were tied down with inclined cables within the hurricane warning time. *FN.*

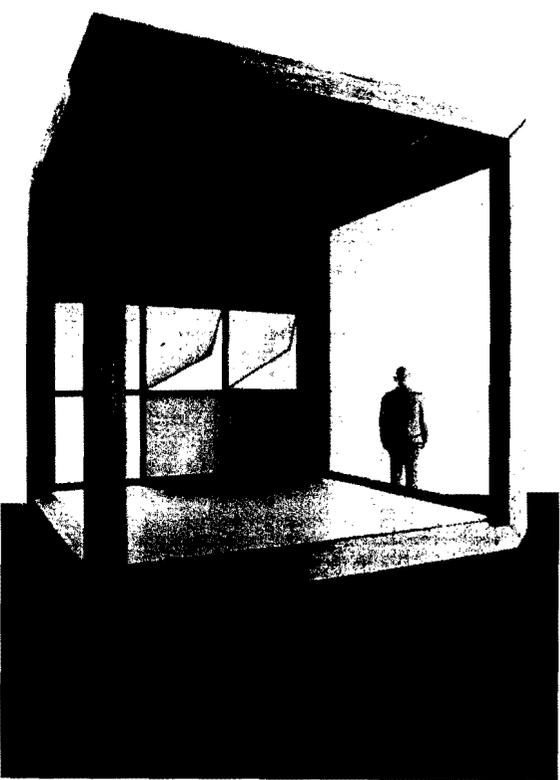
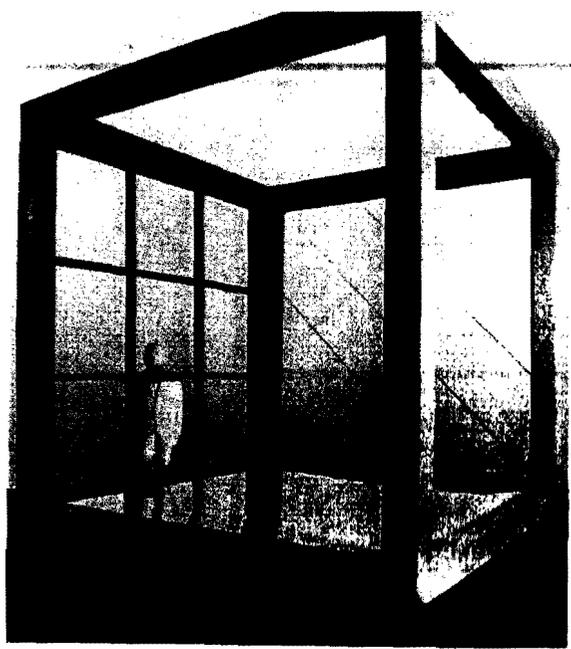

● three typical cubic units and screens and post (bottom right) Double and triple cubed with and infill.

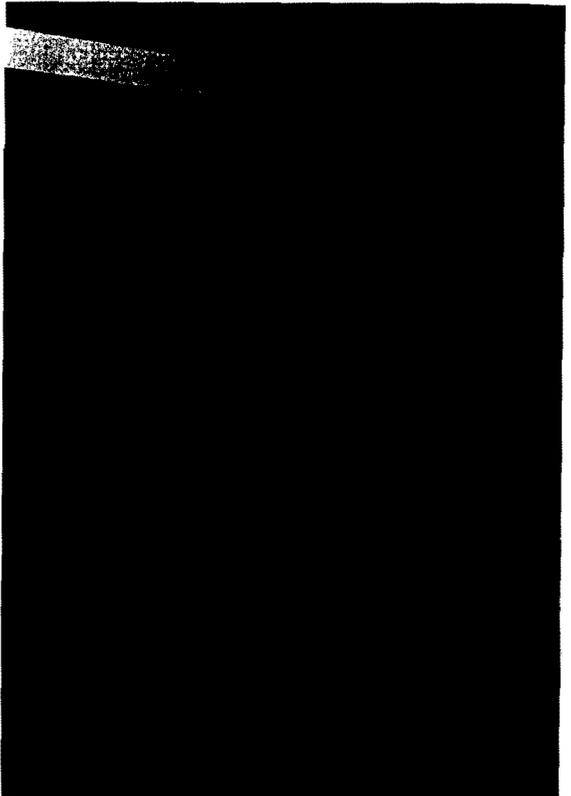

never look



never lo

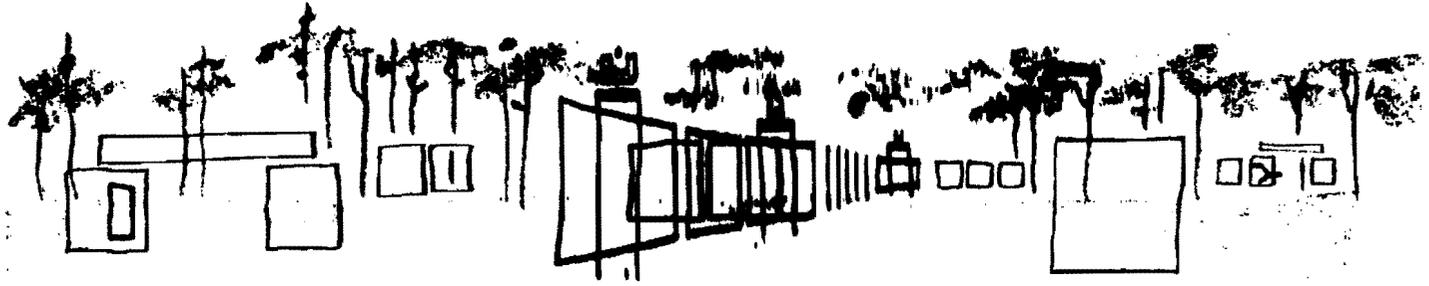

*never look empty, never feel full.*

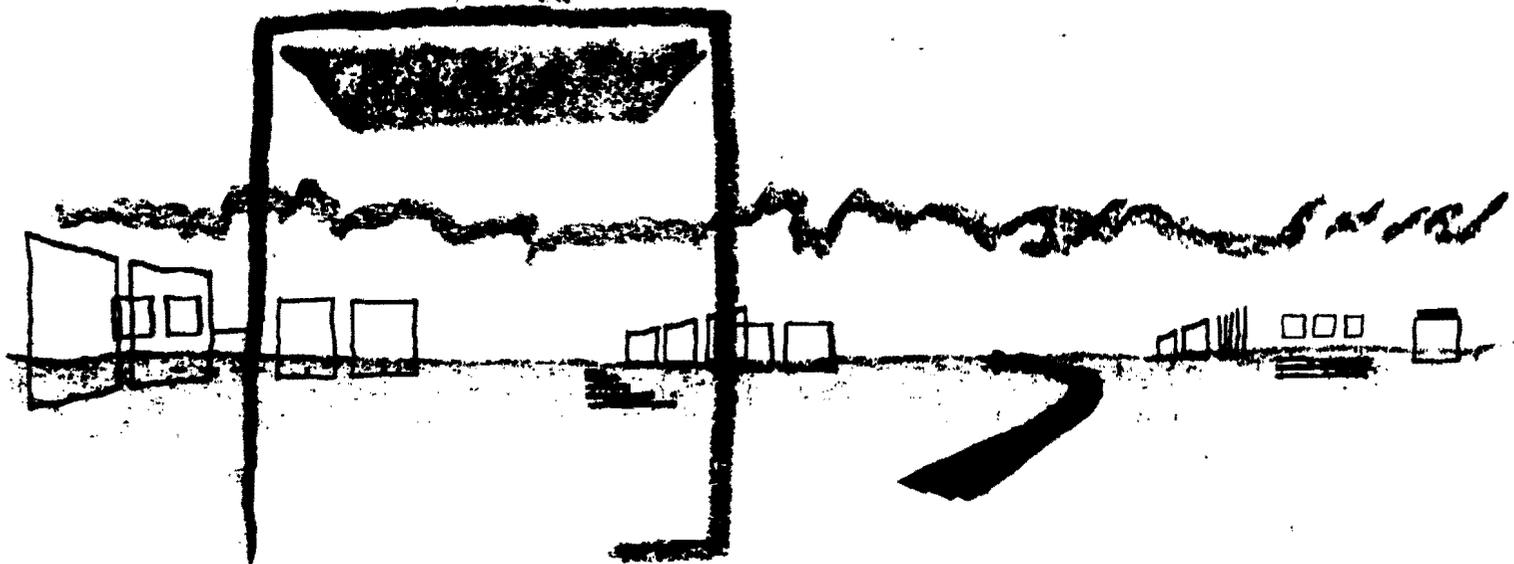

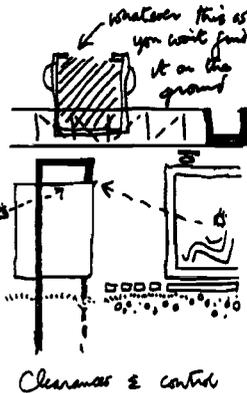
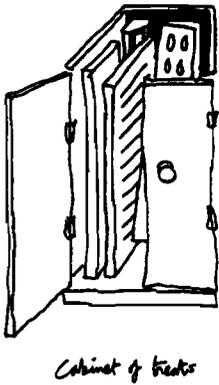
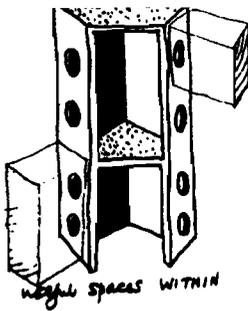

GENERATOR

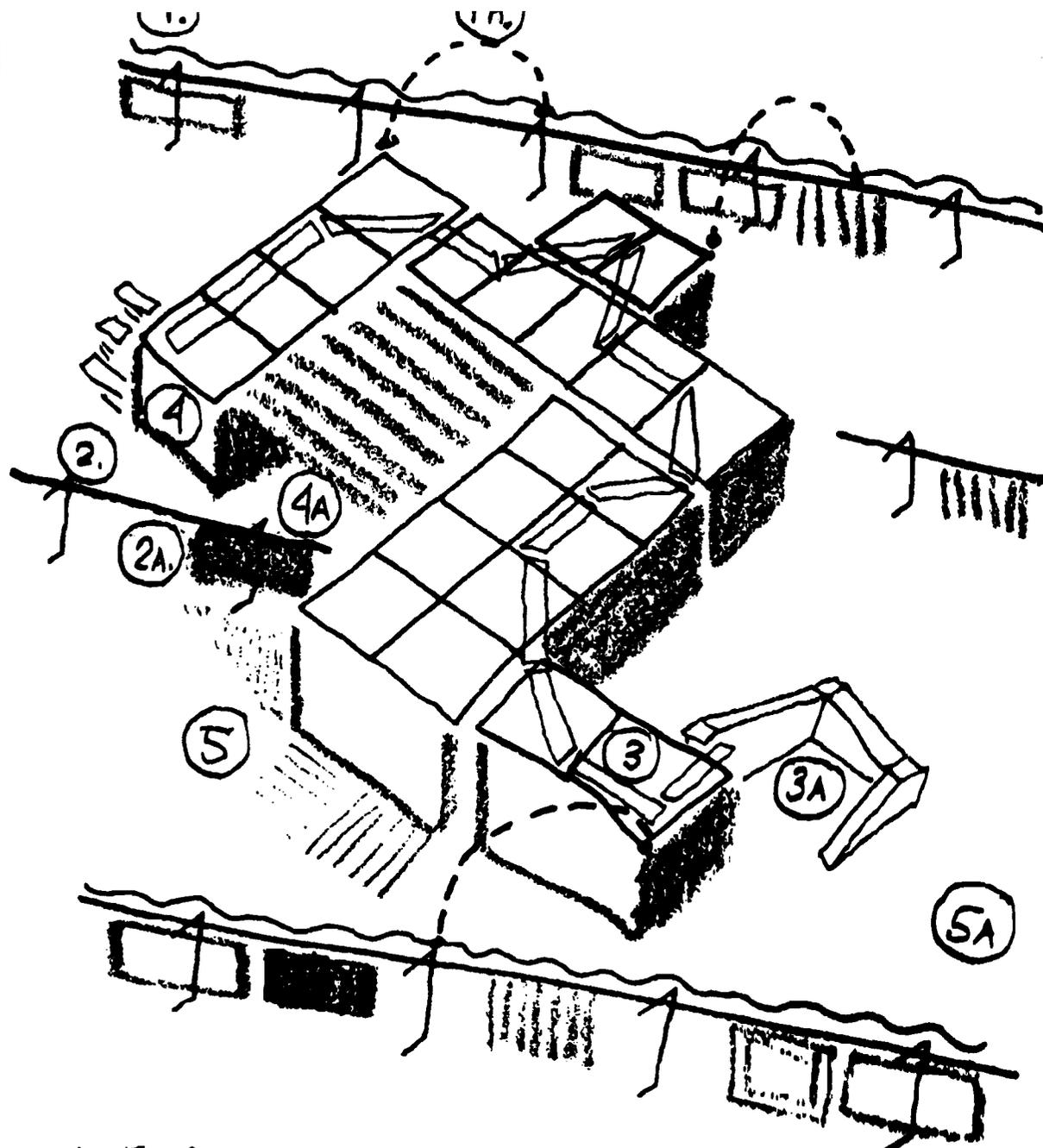

- |            |            |
|------------|------------|
| 1. Feed    | 1A Connect |
| 2. Route   | 2A Control |
| 3. Demand  | 3A Retail  |
| 4. Contain | 4A Extend  |
| 5. Enlarge | 5A Relieve |

BONE & MUSCLE.

A forest facility for be management an friends, or any who environment, sited, of thought.  
In this scheme ar one's own interests

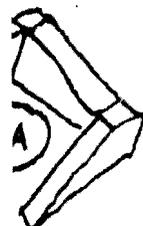

5A

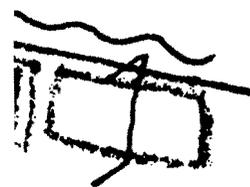

WSCLE

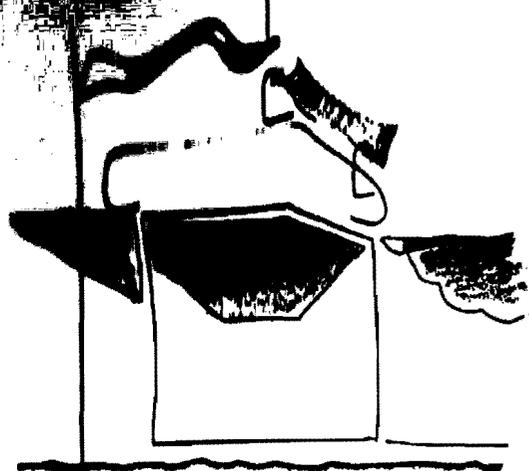

P.

don't forget the undersides.

A forest facility for between one and one thousand visitors, who may be management and labour of the client paper company, clients' friends, or any who are deemed to benefit from this responsive environment, sited, designed and serviced to enrich freedom of thought.

In this scheme architecture is used as an aid to the extension of one's own interests. A series of structures, barriers, fittings and

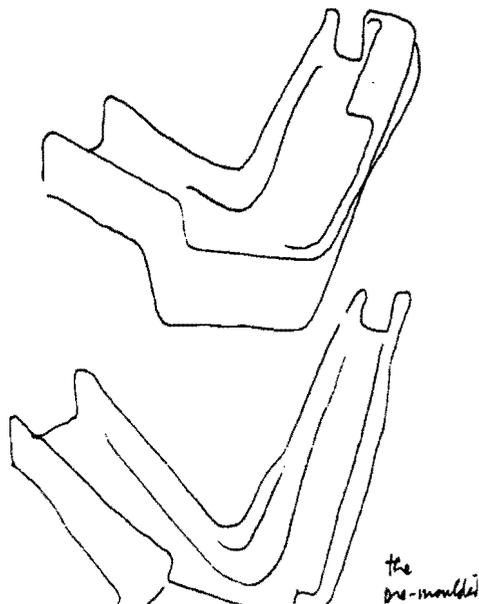

the one-shoulder

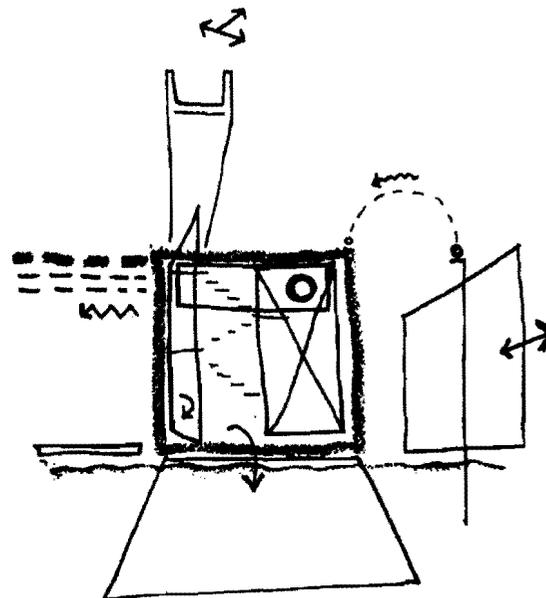

Calculated confusion of similars for disparate ends.

components respond to the appetite that, in some cases, they themselves may generate.

A 'menu' of items caters for individual and group demands for space, control, containment and delight. The built form is primarily laminated, timber-framed structures with variable infills and cladding panels located on a regular grid of concrete and steel pads by means of wheeled crange.

C.P.

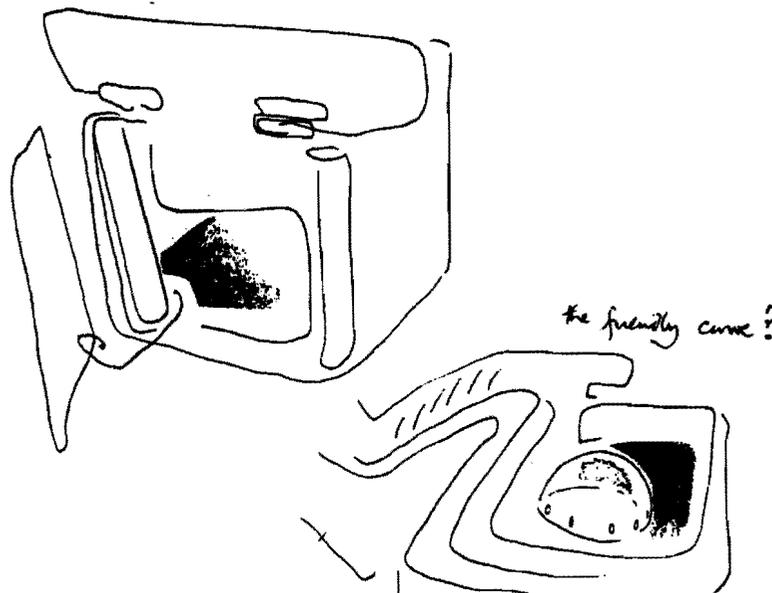

the friendly curve?

